

ELECTRIC STAND IN TOW TRACTOR

BELET a.s. , Dělnická 1253/37, 431 91 VEJPRTY, CZECH REPUBLIC
tel: +420 474 386 333, +420 474 386 338, +420 474 386 686, +420 474 386 381
email: marketing@belet.cz, beletvejprty@belet.cz, odbyt@belet.cz
<http://www.belet.cz> • <http://obchod.belet.cz>

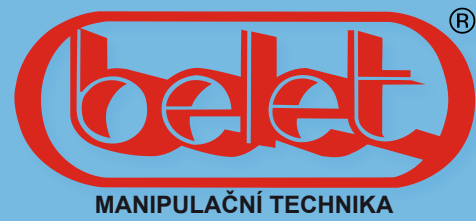

ELECTRIC STAND IN TOW TRACTOR TE 30



Capacity 3.0t



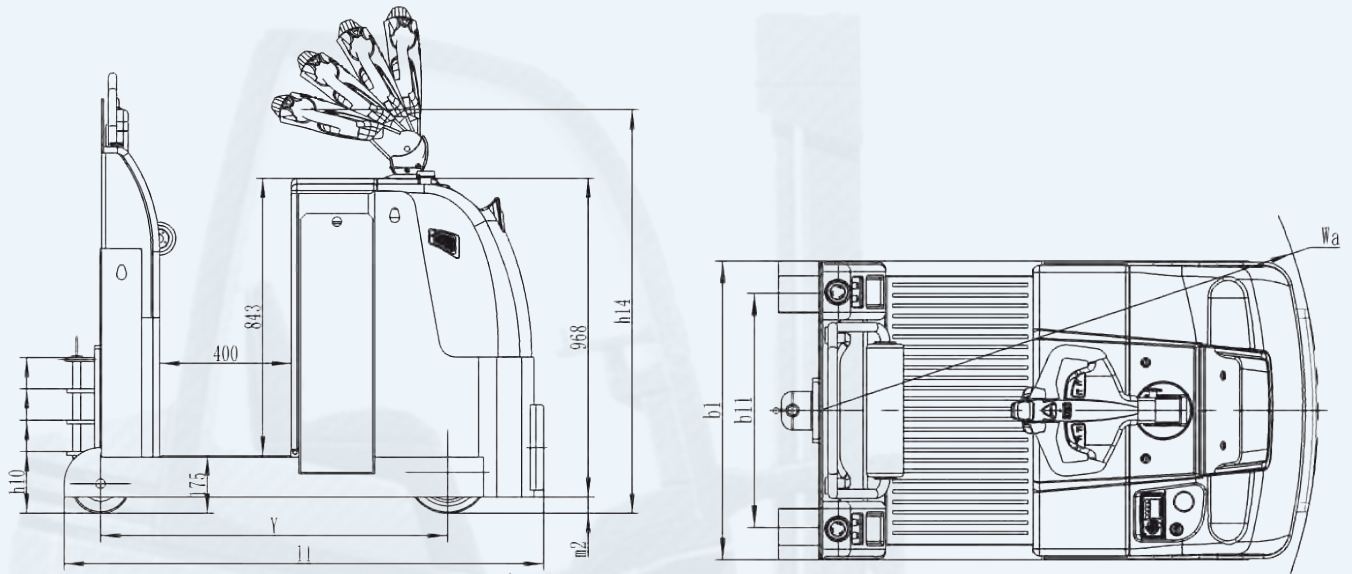

Type				TE 30
Identification	1.3	Power		Battery
	1.4	Operator type		Pedestrian
	1.5	Load Capacity / rated load	Q (t)	3,0
	1.9	Wheelbase	y (mm)	1 051
	2.1	Service weight	kg	920
Weight	2.3	Axle loading, unladen front/rear	kg	560 / 360
	3.1	Tires		R+PU
Wheel chassis	3.2	Tire size, front	(mm)	o 250x82 G
	3.3	Tire size, rear	(mm)	o 180x76 PU
	3.5	Wheels, number front/rear(x=driven wheels)		1x /2
	3.7	Track, rear	b11 (mm)	635
	4.9	Height of tiller in drive position min./ max.	h14 (mm)	1450/1420/1340/1226
Tires, Chassis	4.12	Gripping of the tiller	h10 (mm)	188/283/378/473
	4.19	Overall length	l1 (mm)	1453
	4.21	Overall width	b1 (mm)	810
	4.32	Ground clearance, centre of wheelbase	m2 (mm)	50
	4.35	Turning radius	wa (mm)	1348
	5.1	Travel speed, laden/ unladen	km/h	7.0/7.5
Perfor- mance	5.10	Service brake		Electromagnetic
	6.1	Drive motor rating S2 60min	kw	2,9
E- Motor	6.4	Battery	V/Ah	24 / 465
	6.5	Battery weight	kg	377
		Battery dimensions	L/P/H (mm)	770 / 310 /450
	8.1	Type of drive control		AC- speed control