

# SCHLEPPER MIT FAHRERSITZ

BELET a.s. , Dělnická 1253/37, 431 91 VEJPRTY, CZECH REPUBLIC  
tel: +420 474 386 333, +420 474 386 338, +420 474 386 686, +420 474 386 381  
email: marketing@belet.cz, beletvejprty@belet.cz, odbyt@belet.cz  
http://www.belet.cz • http://obchod.belet.cz

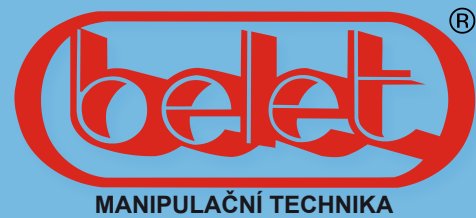

## SCHLEPPER MIT FAHRERSITZ TE 30



*Anhängelast bis 3.0t*



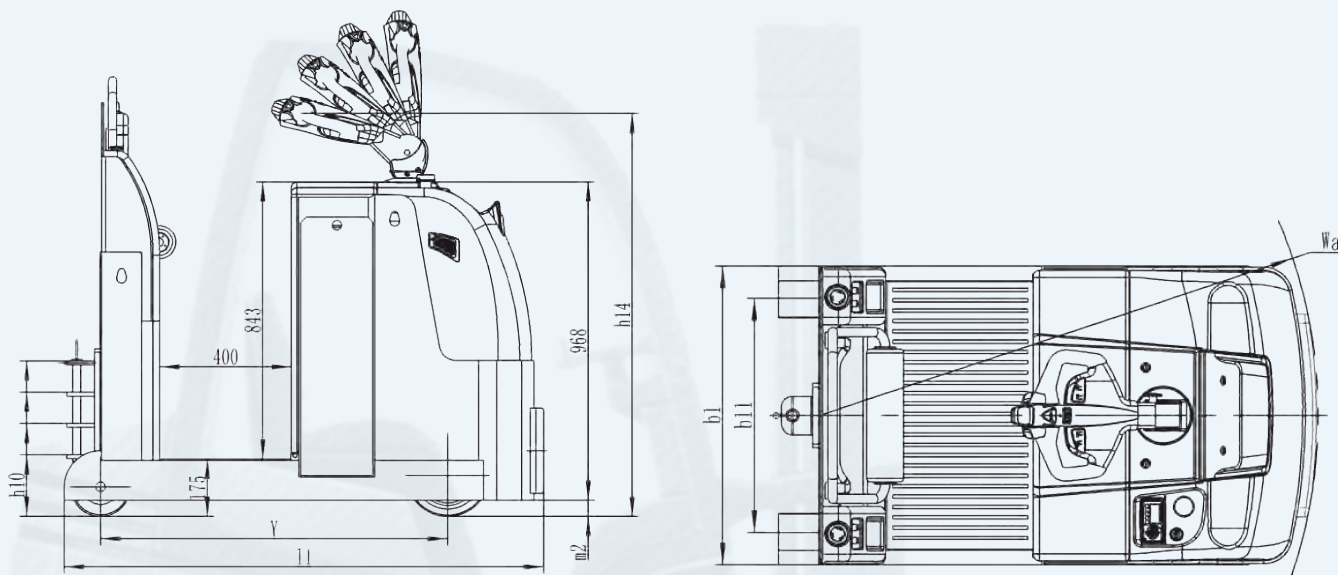

| Typ              |      |   |            | TE 30               |
|------------------|------|---|------------|---------------------|
| Kennzeichen      | 1.3  | Antrieb                                       |            | Elektro             |
|                  | 1.4  | Bedienung                                     |            | Geh                 |
|                  | 1.5  | Tragfähigkeit                                 | Q (t)      | 3,0                 |
|                  | 1.9  | Radstand                                      | y (mm)     | 1 051               |
|                  | 2.1  | Eigengewicht                                  | kg         | 920                 |
| Gewicht          | 2.3  | Achslast ohne Last vorn/hinten                | kg         | 560 / 360           |
|                  | 3.1  | Bereifung                                     |            | Gummi/Polyurethan   |
| Räder            | 3.2  | Vorderrad                                     | (mm)       | o 250x82 G          |
|                  | 3.3  | Hinterrad                                     | (mm)       | o 180x76 PU         |
|                  | 3.5  | Räder Anzahl vorn/hinten (x =Rad mit Antrieb) |            | 1x /2               |
|                  | 3.7  | Spurweite, hinten                             | b11 (mm)   | 635                 |
|                  | 4.9  | Höhe Deichsel in Fahrstellung min./max.       | h14 (mm)   | 1450/1420/1340/1226 |
| Grundabmessungen | 4.12 | Kupplungshöhe                                 | h10 (mm)   | 188/283/378/473     |
|                  | 4.19 | Gesamtlänge                                   | l1 (mm)    | 1453                |
|                  | 4.21 | Gesamtbreite                                  | b1 (mm)    | 810                 |
|                  | 4.32 | Bodenfreiheit Mitte Radstand                  | m2 (mm)    | 50                  |
|                  | 4.35 | Wenderadius                                   | wa (mm)    | 1348                |
|                  | 5.1  | Fahrgeschwindigkeit mit/ohne Last             | km/h       | 7.0/7.5             |
| Leistungsdaten   | 5.10 | Betriebsbremse                                |            | elektromagnetisch   |
|                  | 6.1  | Fahrmotor                                     | kw         | 2,9                 |
| Motor            | 6.4  | Batterie                                      | V/Ah       | 24 / 465            |
|                  | 6.5  | Batteriegewicht                               | kg         | 377                 |
|                  |      | Abmessungen                                   | L/P/H (mm) | 770 / 310 /450      |
|                  | 8.1  | Steuerung                                     |            | elektronisch AC     |