

## ELECTRIC - STACKER

**FX 12AP16/AC**  
**FX 12AP29/AC**  
**FX 12AP36/AC**

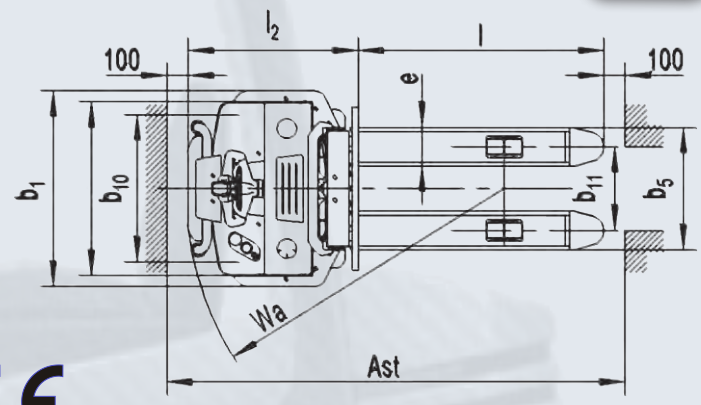

Hub/ Lastschwerpunkt	FX 12APE16/29/AC	
	600 mm	700 mm
3600	800 kg	500 kg
3200	1 000kg	800 kg
2900	1 000 kg	800 kg
2500	1 200 kg	1000 kg
2000	1 200 kg	1 200 kg
1600	1 200 kg	1 200 kg

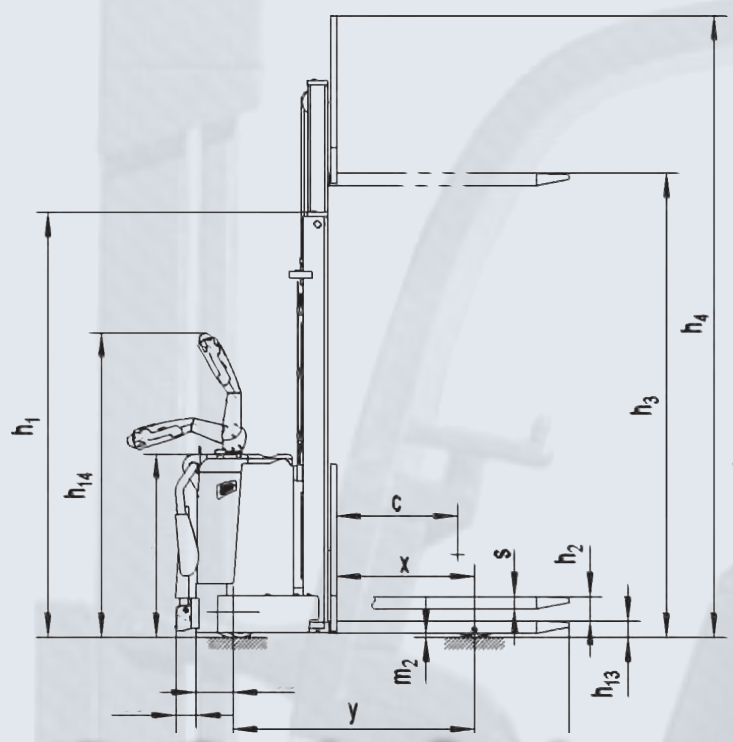

## Technical specification

Type			FX 12AP16/AC	FX 12AP29/AC	FX 12AP36/AC
Identification	Drive motor		electric		
	Steering method		walking		
	Load Capacity / rated load	Q(Kg)	1200		
	Load centre distance	c (mm)	600		
	Distance between driving axle to fork	x(mm)	684		
	Wheel base centre	y(mm)	1196		
Weights	Service weight	kg	850	945	975
	Axle load loaded drive end / load end	kg	780/1270	825/1320	835/1340
	Axle load unloaded drive end / load end	kg	680/170	725/220	735/240
Wheels, Chassis	Tyres		polyurethan		
	Front wheels dimensions	(mm)	252 × 88		
	Back wheels dimensions	(mm)	80 × 70		
	Additional wheels (dimensions)	(mm)	150 × 54		
	Number of front / back wheels		1 driven + 2/4		
	Track width, front	b10(mm)	686		
	Track width, rear	b11(mm)	390		
Dimensions	Height mast lowered	h1(mm)	1976	1946	2296
	Free lift	h2(mm)	1519	120	120
	Lifting height	h3(mm)	1600	2900	3600
	Height mast extended	h4(mm)	2375	3675	4375
	Handle height in driving position min./max	h14(mm)	985/1420		
	Min. fork height	h13(mm)	81		
	Overall length	l1(mm)	1846		
	Length to fork face	l2(mm)	695		
	Overall width	b1(mm)	910		
	Fork dimensions	s/e/l(mm)	60/180/1150		
	Overall fork width	b5(mm)	570		
	Ground clearance, centre of wheel base	m2(mm)	26		
	Working aisle with pallet 1000X1200 crossways	Ast(mm)	2320		
	Working aisle with pallet 800X1200 lengthwise	Ast(mm)	2215		
	Turning radius	Wa(mm)	1400		
Performance	Driving speed with load / without load	km/h	6/6		
	Lifting speed with load / without load	mm/s	105/150		
	Lowering speed with load / without load	mm/s	130/110		
	Max. performance with load / without load	%	6/12		
	Service brake		electromagnetic		
Motor	Drive motor rating s2 60min	kW	1,3		
	Lift motor rating s3 15%	kW	2,2		
	Battery voltage, nominal capacity	V/Ah	24/240		
Others	Driving control type		AC speed control		
	Sound level according EN 12053	dB(A)	<70		